

Parapet Wall Anchor

Parapet Wall Anchor

A SAS exclusive design, our No.1097 Parapet Wall Anchor offers features not found in other wall clamps. Easily adjusts to varying wall thickness with 12 different positions and fitted with SAS No.1090 cast loop top. Compatible with many guardrail systems, our clamp features two 5/8" bolts with welded nuts that provide a strong compression lock to hold guardrail stanchions in place with the twist of a wrench.

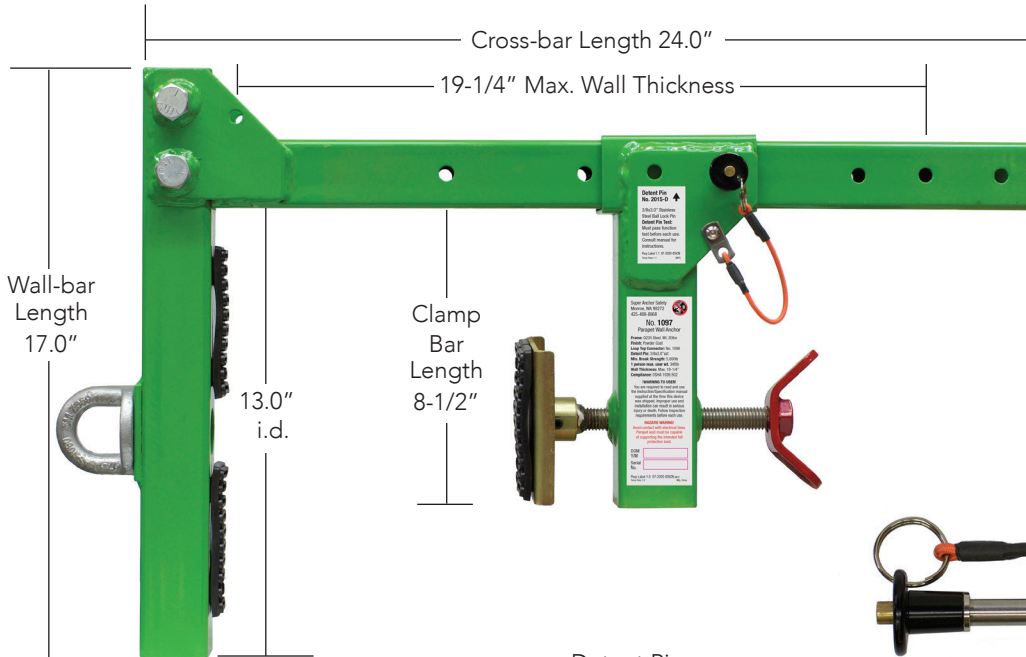

No.1097 Specifications

- 1/8"x2"x2" steel tube.
- Safety green powder coating
- 12 adjustment points
- Max. width 19-1/4"
- No.2015-2.9-4 detent pin w/shock cord tether.
- 1-3/4"x1-3/4" i.d. stanchion sockets
- 2ea 5/8"-11x 1-3/4" grade 5 stanchion bolts
- Clamp weight 23lbs.

No.2015-2.9-4 3/8"sst Detent Pin



Detent Pin
w/shock cord tether.

Shock Cord Tether



No.1090
Cast Steel
Loop
Top

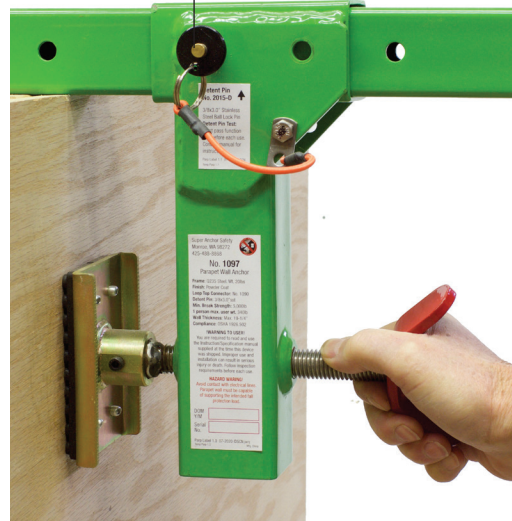

5/8" Stanchion Bolts
w/weld nuts



Safety Rail
Stanchion
1-3/4"x1-3/4"
max. o.d