



# SUPER ANCHOR SAFETY

FALL PROTECTION  
EQUIPMENT

Best Selling  
Products

Volume 1

[www.superanchor.com](http://www.superanchor.com)

1-855-301-4575

# Table of Contents



| Pg. | Part Name   |
|-----|---|
|     | <b>Residential Anchors</b>  |
| 1   | 2815 Retro-Fit™<br>2813 RS-10™<br>2816 RS-20™<br>2815-T Tile-Retro-Fit™   |
| 2   | 1075 D-Minus™<br>3013-D Hinge-2™<br>1019 Form-IT™<br>1029 D-ShakL™  |
| 3   | Evac™<br>2100 Flex™<br>Value™ Tie-Off Straps<br>3005-CB Tie-Off Straps  |
| 4   | AR™ 2x4<br>AR™ 2x8<br>1004 Vertical Wall Low Slope<br>1004-A Vertical Wall Steep Slope                                    |
|     | <b>Safety Bars</b>  |
| 5   | 2833 2x4/2x6 Truss Bar™<br>1012 2x4/2x6 Combo Safety Bar™<br>1017-A 2x4 Web Joist Safety Bar™<br>2835 WS Attic Truss Bar™ |
|     | <b>Commercial Anchors</b>   |
| 6   | CRA Base Plate Anchors<br>RLT Field Weld Risers<br>CRO CAL-OSHA Base Plate Anchor<br>CRR CAL-OSHA Field Weld Risers       |
|     | <b>D-Plates/Backer Plates</b>   |
| 7   | 1037/1301 D-Plate Anchors<br>Backer Plates  |
|     | <b>HLL System Components</b>  |
| 8   | 4-Way Anchors/4-Way<br>HLL Rigging Kits/Cable   |
| 9   | <b>Fasteners/Carabiners</b>   |
|     | <b>Full Body Harnesses</b>  |
| 10  | Deluxe™/Deluxe™ w/Tool Bags   |
| 11  | Ultra-Viz™/ Ultra-Viz™ w/Tool Bags  |
| 12  | Tongue Buckle Harnesses   |
| 13  | Front D-ring Harness  |
| 14  | Pro-Deluxe™ / Fall Arrester™ Harnesses  |

# Table of Contents



| Pg. | Part Name                                |
|-----|--|
|     | <b>All-Pakka™ Tool Bags</b>              |
| 15  | Tool Bags / Utility Belt                 |
| 16  | Tool Bag Combo / Padded Waist Belts      |
|     | <b>Energy Absorbers</b>                  |
| 17  | Personal Energy Absorbers                |
| 18  | Flex Energy Absorbing Lanyards           |
|     | <b>Lanyards</b>                          |
| 19  | Extender Web Lanyards                    |
| 20  | Adjustable Rope Lanyard                  |
|     | 2-D Lanyards                             |
| 21  | Adjustable/Fixed Length Web Lanyards     |
|     | <b>Fall Protection Bucket Kits</b>       |
| 22  | 3200-B Max-V™                            |
| 23  | 3001 MAX™                                |
|     | <b>Lifelines</b>                         |
| 24  | Deluxe™ 12 Strand                        |
|     | Value™ 3 Strand                          |
|     | Maxima™ 3 Strand                         |
|     | <b>Rope Grabs</b>                        |
| 25  | 4015-Z Fall Arrester                     |
|     | 4015-M Integral Adjuster                 |
|     | 4015 SuperGrab™                          |
|     | 4015-V ValueGrab™                        |
|     | <b>Self Retracting Lifelines (SRL's)</b> |
| 26  | SideWinder™                              |
| 27  | TossR™                                   |
|     | <b>Accessories</b>                       |
| 28  | Cargo Bags                               |
|     | Trauma Suspension Ladder™                |
| 29  | Tool Tethers                             |
|     | Lanyard Park                             |
| 30  | Ladder Leash™                            |

# Permanent Anchors

## No.2815 Retro-Fit™

- Industry standard for shingle roofing
- Ideal for new or reroofing
- Fall arrest/fall restraint
- **Leg:** 2 layers 20ga 430sst
- **D-rings:** Dacromet coated
- Date of mfg. stamp
- 8pc 12d sst spiral shank nails
- 2pc 5" butyl flashing strip
- English/Spanish/French manuals
- ANSI Z359.18-17 type A
- CSA Z259.15.22 type A ▲
- ▲ *Canadian 3rd party engineering report provided upon request.*



Length 13.0"  
Width 2.0"  
Ridge or field installation  
conforms to any slope.

### Ordering Information

| Part No. | Package | Pcs | wt.  |
|----------|---------|-----|------|
| 2815     | Retail  | 1   | 1lb  |
| 2815-B   | Bulk    | 20* | 23lb |

\*Min.order 20pcs

## No.2813 RS-10™

- Shingle roofing anchor
- Ideal for new or reroof
- Fall arrest/fall restraint
- **Leg:** 2 layers 20ga 430sst
- **D-ring:** Dacromet coated
- Date of mfg. stamp
- 8pc 12d sst spiral shank nails
- 1pc 7" butyl flashing strip
- English/Spanish manuals
- ANSI Z359.18-17 type A
- CSA Z259.15.22 type A ▲



Length 8-1/2"  
Width 2.0"

### Ordering Information

| Part No. | Package | Pcs | wt.  |
|----------|---------|-----|------|
| 2813     | Retail  | 1   | .5lb |
| 2813-B   | Bulk    | 20* | 12lb |

\*Min.order 20pcs

## No.2816 RS-20™

- Shingle or tile roofing
- Ideal for new or reroofing
- Fall arrest/fall restraint
- **Leg:** 2 layers 20ga 430sst
- **D-ring:** Dacromet coated
- Date of mfg. stamp
- 8pc 12d sst spiral shank nails
- 2pc 7" butyl flashing strip
- English/Spanish manuals
- ANSI Z359.18-17 type A
- CSA Z259.15.22 type A ▲



Length 17-1/2" Width 2.0"

Ridge or field installation  
conforms to any slope.

### Ordering Information

| Part No. | Package | Pcs | wt.  |
|----------|---------|-----|------|
| 2816     | Retail  | 1   | 1lb  |
| 2816-B   | Bulk    | 20* | 23lb |

\*Min.order 20pcs

## No.2815-T Tile-Retro™

- Shingle or Tile roofing
- Ideal for new or reroofing
- Fall arrest/fall restraint
- **Leg:** 1 layer 14ga 430sst
- **D-rings:** Dacromet coated
- Date of mfg. stamp
- 16pc 12d sst spiral shank nails
- 4pc 7" butyl flashing strip
- English manual
- ANSI Z359.18-17 type A
- CSA Z259.15.22 type A ▲



Length 40" Width 2.0"

Ridge or field installation  
conforms to any slope.

### Ordering Information

| Part No. | Package | Pcs | wt.  |
|----------|---------|-----|------|
| 2815-T   | Single  | 1   | 1lb  |
| 2815-TBB | Bulk    | 20* | 53lb |

\*Min.order 20pcs

1

# Permanent/Temporary Anchors

## No.1075 D-Minus™

US Pat.8746402

- Permanent or temporary anchor
- Ideal for new or reroofing
- Fall arrest/fall restraint
- 11 gauge zinc plated powder coated steel
- Date of mfg. stamp
- 60pc 12d sst spiral shank nails
- 10pc 7" butyl flashing strips
- English/Spanish manual
- ANSI Z359.18-17 type A
- CSA Z259.15.22 type A

### Ordering Information

| Part No. | Package    | Pcs | wt.  |
|----------|------------|-----|------|
| 1075     | Retail Box | 10  | 7lb  |
| Δ1075-S  | Retail Box |     |      |
| 1075-B   | Bulk Box*  | 80  | 48lb |

Δ 430 Stainless Steel  
\*Order nails and butyl separately

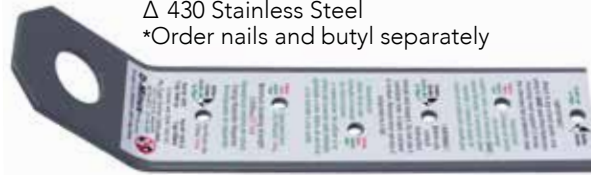

No.2013  
SST Nails



Length 9.0"  
Width 2.0"

No.2043-7  
Butyl Strips



## No.3013-D Hinge-2™

- Temporary/reusable anchor
- Fall arrest/fall restraint/HLL
- Wood or metal decking
- 11 gauge dacromet plated steel
- Forged D-ring
- Dual size fastener holes for multiple fastener options
- Date of mfg. stamp
- 36pc 16d duplex nails\*
- English/Spanish manual
- ANSI Z359.18-17 type A
- CSA Z259.15.22 type A

\*Fastener options available

### Ordering Information

| Part No. | Package | Pcs | wt. |
|----------|---------|-----|-----|
| 3013-D   | Retail  | 1   | 3lb |

No.2012-A  
Duplex  
Nails



Retail Package



3/16" Holes

Leg Length 9.0"

5/16" Holes

Width 3.0"



## No.1019 Foryst™

FORYST™  
REUSABLE FALL PROTECTION FOR MULTIPLE ANCHORS

- Lowest cost single use anchor
- Fall arrest/fall restraint
- 14 gauge zinc plated steel
- Date of mfg. stamp
- 16d vinyl coated nails
- English/Spanish manual
- ANSI Z359.18-17 type A
- CSA Z259.15.22 type A

### Ordering Information

| Part No. | Package              | Pcs | Nails | wt.          |
|----------|----------------------|-----|-------|--------------|
| 1019     | Retail Box           | 10  | 100   | 11lb         |
| 1019-3   | Retail Package       | 3   | 30    | 3lb          |
| 1019-B   | 2ea. 50pc Bulk Boxes | 100 | 1000  | 43lb ea. box |

16d Nails



10pc  
Box



Retail Package

Leg Length 5-7/8"

Width 2.0"



## No.1029 D-Shakl<sup>2</sup>™

- Permanent or temporary anchor
- Fall arrest/fall restraint/HLL
- 1/4" HDG coated steel
- Forged D-ring w/captive backer
- Bolt, weld, or wood screw attached
- Permanent use label pack
- Dual hole sizes
- English manual
- Fasteners not included
- ANSI Z359.18-17 type A
- CSA Z259.15.22 type A

### Ordering Information

| Part No. | Package        | Pcs | wt. |
|----------|----------------|-----|-----|
| 1029     | Retail Package | 1   | 1lb |
| Δ1029-S  |                |     |     |

Δ 316 Stainless Steel

Permanent  
Label Pack



Retail Package



3/16" Holes

Leg Length 4-7/8"

5/16" Holes

Width 2.0"



# Temporary Anchors/Tie-Off Straps

## E-Vac™ Anchor

US Pat. 8,746,402-B2

- Specified for 2x4, 2x6, 2x8 top chords
- Temporary reusable anchor
- Fall arrest/fall restraint
- Install inverted for attic anchor
- 11 gauge zinc plated steel
- Date of mfg. stamp
- Hex bolt w/lock nut
- Evac tether strap
- English manual
- ANSI Z359.18-17 type A
- CSA Z259.15.22 type A

## Ordering Information

| Part No. | Package        | Pcs | wt.    |
|----------|----------------|-----|--------|
| 1062 2x4 | Retail Package | 1   | 1lb    |
| 1063 2x6 |                |     | 1.25lb |
| 1064 2x8 |                |     | 1.5lb  |

Bulk box orders on request

Attachment Bolt 5/16" x 1-1/2"



Retail Package



## No.2100 Flex™

- Temporary anchor conforms to any slope
- Fall arrest/fall restraint/HLL
- 1/4" zinc plated steel legs
- 3" d. forged D-ring
- Type 80 chain
- Dual hole sizes
- Date of mfg. stamp
- English/Spanish manual
- 2 fastener packs
- ANSI Z359.18-17 type A
- CSA Z259.15.22 type A

## Ordering Information

| Part No. | Package    | Pcs | wt. |
|----------|------------|-----|-----|
| 2100     | Retail Box | 1   | 5lb |

Retail Box



## Value™ Tie-Off Straps

- Lowest cost tie-off strap
- Fall arrest/fall restraint
- 2" x 7, 425lb strength polyester
- Zinc plated stamped D-ring
- Loop end chinch
- Inspection/serial no. label
- English/Spanish manual
- USA mfg. on request
- ANSI Z359.18-17
- CSA Z259.15.22

## Ordering Information

| Part No. | Length | Package        | Pcs | wt.    |
|----------|--------|----------------|-----|--------|
| 6050-D   | 36"    | Retail Package | 1   | .75lb  |
| 6051-D   | 48"    |                |     | 1.0lb  |
| 6052-D   | 60"    |                |     | 1.25lb |
| 6053-D   | 72"    |                |     | 1.5lb  |
| 6050-DB  | 36"    | Bulk Box       | 50  | 34lb   |
| 6051-DB  | 48"    |                |     | 38lb   |
| 6052-DB  | 60"    |                |     | 44lb   |
| 6053-DB  | 72"    |                |     | 48lb   |

Retail Package



Cinch Style



Bulk Box

## No.3005 Tie-Off Straps™

- 2" x 13, 600lb strength polyester
- Fall arrest/fall restraint
- Zinc plated stamped D-ring
- Loop end chinch
- Inspection/serial no. label
- English/Spanish manual
- ANSI Z359.18-17
- CSA Z259.15.22

## Ordering Information

| Part No. | Length | Package     | Pcs | wt.  |
|----------|--------|-------------|-----|------|
| 3005-C   | 48"    | Retail Pkg. | 1   | .5lb |
| 3005-CB  |        | Bulk Box    | 50  | 39lb |

Bulk Box



Cinch Style



Retail Pkg.



# Permanent Residential Anchors

## ARS™ 2x4

- Permanent bolt attached anchor
- Fall arrest/fall restraint
- Fits 2x4 top chords
- 14ga 430 stainless steel
- Date of mfg. stamp
- PVC flashing base
- PVC stem cover w/tether
- Fastener pack
- English/Spanish/French manual
- ANSI Z359.18-17 type D
- CSA Z259.15.22 type AD
- **Canadian 3rd party engineering. Report provided upon request**

## Ordering Information

| Part No. | Package     | Pcs | wt.   |
|----------|-------------|-----|-------|
| 2830     | Retail Pkg. | 1   | 2lb   |
| Δ1022    |             |     |       |
| 1030     | Retail Box  | 6   | 12lb  |
| 1030-B   | Bulk Box    | 50* | 100lb |

Δ Does not include base/stem flashing  
\* **Min. order 50pcs**



## ARS™ 2x8

- Permanent bolt attached anchor
- Fits 2x4, 2x6, 2x8 top chords
- Fall arrest/fall restraint
- 14ga 430 stainless steel
- Date of mfg. stamp
- PVC flashing base
- PVC stem cover w/tether
- Fastener pack
- English/Spanish/French manual
- ANSI Z359.18-17 type D
- CSA Z259.15.22 type AD
- **Canadian 3rd party engineering. Report provided upon request**

## Ordering Information

| Part No. | Package     | Pcs | wt.   |
|----------|-------------|-----|-------|
| 2801     | Retail Pkg. | 1   | 2lb   |
| Δ1006    |             |     |       |
| 1001     | Retail Box  | 6   | 12lb  |
| 1001-B   | Bulk Box    | 50* | 100lb |

Δ Does not include base/stem flashing  
\* **Min. order 50pcs**



## No.1004 Wall Mount™

- Permanent bolt attached anchor for exterior wall sized for 2x6, 2x8 top plates
- Fall arrest/fall restraint
- Specify for slopes under 7/12
- 11ga 430 stainless steel
- Date of mfg. stamp
- Fastener pack
- English manual
- ANSI Z359.18-17 D
- CSA Z259.15.22 AD

## Ordering Information

| Part No. | Package     | Pcs | wt.   |
|----------|-------------|-----|-------|
| 1004     | Retail Pkg. | 1   | 1.4lb |

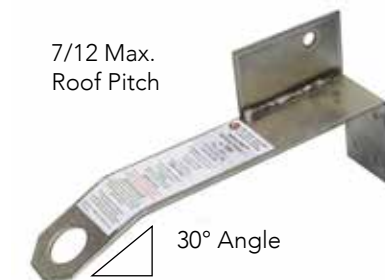

## No.1004A Wall Mount™

- Permanent bolt attached anchor for exterior wall sized for 2x6, 2x8 top plates
- Fall arrest/fall restraint
- Specify for slopes over 7/12
- 11ga 430 stainless steel
- Date of mfg. stamp
- Fastener pack
- English manual
- ANSI Z359.18-17 D
- CSA Z259.15.22 AD

## Ordering Information

| Part No. | Package     | Pcs | wt.   |
|----------|-------------|-----|-------|
| 1004A    | Retail Pkg. | 1   | 1.4lb |

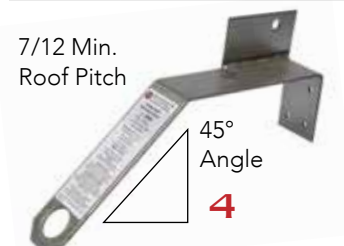

# Top Chord Safety/Truss/Attic Bars

## No.2833-DP Truss Bar™

- Moveable/temporary anchor fits 2x4 and 2x6 top chords spaced 24.0" centers
- 2 person fall arrest/fall restraint
- 2ea 24" removable D-ring tie-off straps
- 3/8" SST detent pin w/shock cord
- Powder coated steel
- English/Spanish/French manuals
- ANSI Z359.18-17 type A
- CSA Z259.15.22 type A
- Canadian 3rd party engineering. Report provided upon request

## Ordering Information

| Part No. | Package | Pcs | wt.   |
|----------|---------|-----|-------|
| 2833-DP  | Box     | 1   | 6.5lb |
| Δ 2833   |         |     | 5.5lb |

Δ Supplied with hex bolts.

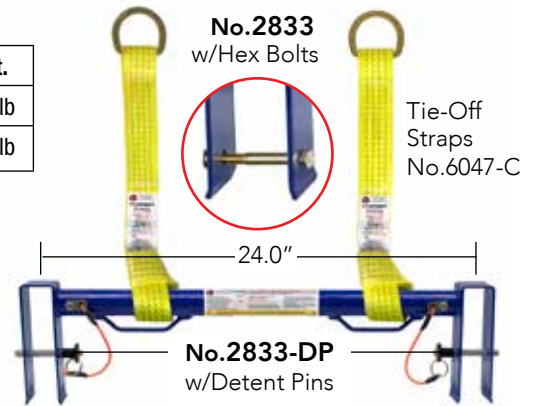

## No.1012 Safety Bar™

- Moveable/temporary anchor
- 2 person fall arrest/fall restraint
- Fits 2x4 and 2x6 top chords
- 48.0" length w/legs spaced 24.0" o.c.
- 3/8" SST detent pin w/shock cord
- Powder coated steel
- English/Spanish/French manuals
- ANSI Z359.18-17 type D
- CSA Z259.15.22 type AD
- Canadian 3rd party engineering. Report provided upon request

## Ordering Information

| Part No. | Package | Pcs | wt.  |
|----------|---------|-----|------|
| 1012     | Box     | 1   | 12lb |

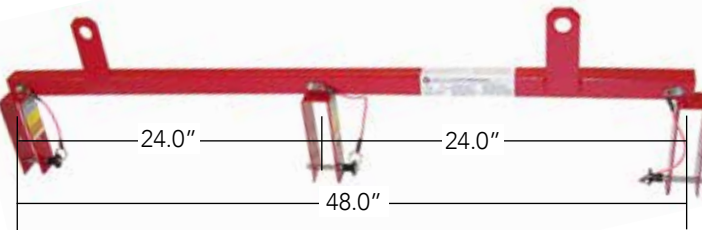

Detent Pin No.2015-2.2-8 w/ Shock Cord Tether



## No.1017-A Joist Safety Bar™

- Moveable/temporary anchor
- 2 person fall arrest/fall restraint
- Fits 2x4 web trusses
- 48.0" length w/legs spaced 24.0" o.c.
- 3/8" SST detent pin w/shock cord
- Powder coated steel
- English/Spanish manuals
- ANSI Z359.18-17 D
- CSA Z259.15.22 AD

## Ordering Information

| Part No. | Package | Pcs | wt.  |
|----------|---------|-----|------|
| 1017-A   | Box     | 1   | 17lb |

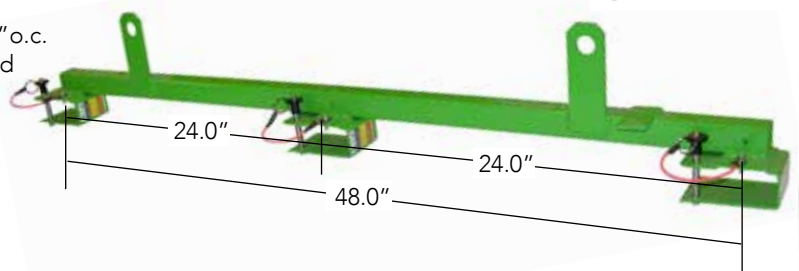

Detent Pin No.2015-2.2-6 w/ Shock Cord Tether

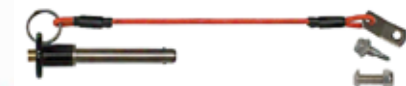

## No.2835 Attic Truss Bar

- Moveable/temporary anchor
- 1 person fall arrest/restraint
- Adjustable to fit 12", 16", 24" spaced 2x top chords/rafters
- 6mm 5052 grade aluminum
- 25pc 2.0" WS screws w/driver
- Specified for SRL's and HLL's
- English/Spanish manuals
- ANSI Z359.18-17 type A
- CSA Z259.15.22 type A

## Ordering Information

| Part No. | Package | Pcs | wt.   |
|----------|---------|-----|-------|
| 2835     | Box     | 1   | 6.5lb |



No.2084-2.0 WS Screws w/3/8" Nut Driver





# Commercial Anchors

## CRA Base Plate Anchors

- Permanent PPE/window washing/HLL's
- Screw/bolt/field weld/concrete embedment installation
- 5,000lb min. tensile strength
- Hot dip galvanized or 304sst
- Serial no. tag
- Foam filled riser
- English manual
- 100% USA mfg. on request

## Compliance

All anchors shown here have the following 3rd party certifications:

- ANSI Z359.18-17 type A/T\*
  - CSA Z259.15.22 type AT\*
  - Window Washing ANSI/IWCA 1.14.1
- \*3rd party engineering and certified lab test reports upon request

## CRA Cast Loop Tops

1-3/8" o.d. cast Q235 steel and 316sst one piece loop tops.

## CRA



## CRA Ordering Information

| Part Name | Part No. | Riser Ht. | Sch | Diam | Base Plate   | Type    | wt.  |
|-----------|----------|-----------|-----|------|--------------|---------|------|
| △ CRA-12W | 1032-W   | 12"       | 40  | 3.0" | 16"x16"x3/8" | 52 Hole | 38lb |
| △ CRA-18W | 1033-W   | 18"       |     |      |              |         | 40lb |
| ▲ CRA-24W | 1042-W   | 24"       | 80  |      | 16"x16"x5/8" | 16 Hole | 67lb |

△ Supplied with 40pc screws ▲ Does not include attachment bolts

## RLT Field Weld Risers

- Same material and dimensions as CRA without a base plate
- Specified for field weld to structural steel
- Not supplied with foam filling
- 100% USA mfg. on request

## RLT Ordering Information

| Part Name | Part No. | Riser Ht. | Sch | Diam | wt.    |
|-----------|----------|-----------|-----|------|--------|
| RLT-12W   | 1044-WG  | 12"       | 40  | 3.0" | 6.9lb  |
| RLT-18W   | 1045-WG  | 18"       |     |      | 10.4lb |
| RLT-24W   | 1046-WG  | 24"       | 80  |      | 17.5lb |

## RLT



## CRO Base Plate Anchors

- Complies with CAL-OSHA Title 8
- Permanent PPE/window washing/HLL's
- Bolt/field weld/concrete embedment installation
- 5,000lb min. tensile strength w/no permanent deformation
- 2.0" i.d. cast loop top

- Hot dip galvanized or 304sst
- Foam filled riser
- English manual
- 100% USA mfg. on request

## CRO/CRR Cast Loop Tops

2.0" i.d. cast Q345 steel and 316sst one piece loop tops.

## CRO



## CRO Ordering Information

| Part Name | Part No. | Riser Ht. | Sch | Diam | Base Plate   | Type   | wt.  |
|-----------|----------|-----------|-----|------|--------------|--------|------|
| CRO-12    | 1401-G   | 12"       | 80  | 4.5" | 12"x12"x3/4" | 4 Hole | 49lb |
| CRO-18    | 1402-G   | 18"       |     |      |              | 8 Hole | 56lb |
| CRO-24    | 1403-G   | 24"       |     |      |              | 8 Hole | 64lb |

## CRR Field Weld Risers

- Same material and dimensions as CRO without a base plate
- Specified for field weld to structural steel
- Not supplied with foam filling
- 100% USA mfg. on request

## CRR Ordering Information

| Part Name | Part No. | Riser Ht. | Sch | Diam | wt.  |
|-----------|----------|-----------|-----|------|------|
| CRR-12    | 1202-G   | 12"       | 80  | 4.5" | 19lb |
| CRR-18    | 1203-G   | 18"       |     |      | 25lb |
| CRR-24    | 1204-G   | 24"       |     |      | 33lb |

## CRR



# D-Plates/Backer Plates

## No.1037 D-Plate

- Permanent PPE/window washing/HLL's
- Bolt/field weld/concrete embedment installation
- 5,000lb min. tensile strength
- 1-3/8" i.d. cast loop top
- Hot dip galvanized
- English manual
- 100% USA mfg. on request
- ANSI Z359.18-17 type A/T\*
- CSA Z259.15.22 type AT
- Window Washing ANSI/IWCA 1.14.1

## Ordering Information

| Part Name    | Part No. | Base Plate | Type   | wt.   |
|--------------|----------|------------|--------|-------|
| D-Plate      | 1037-G   | 6"x6"x3/8" | 4 Hole | 5lb   |
| Δ D-Plate    | 1037-S   |            |        | 3.5lb |
| Backer Plate | 1039-R   |            |        |       |

Δ 304 Stainless Steel.

Note: D-Plates not supplied w/attachment bolts

\*3rd party engineering and certified lab test reports upon request



Cast Steel Loop Top

Base Plate

## No.1301 D-Plate

- Complies with CAL-OSHA
- Permanent PPE/window washing/HLL's
- Bolt/field weld/concrete embedment installation
- 5,000lb min. tensile strength
- 2.0" i.d. cast loop top
- Hot dip galvanized or 304sst
- English manual
- 100% USA mfg. on request
- ANSI Z359.18-17 type A/T\*
- CSA Z259.15.22 type AT

## Ordering Information

| Part Name    | Part No. | Base Plate | Type   | wt.   |
|--------------|----------|------------|--------|-------|
| D-Plate      | 1301-G   | 6"x6"x3/8" | 4 Hole | 5lb   |
| Δ D-Plate    | 1301-S   |            |        | 3.5lb |
| Backer Plate | 1039-R   |            |        |       |

Δ 304 Stainless Steel.

Note: D-Plates not supplied w/attachment bolts

- Window Washing ANSI/IWCA 1.14.1
- \*3rd party engineering and certified lab test reports upon request



Cast Steel Loop Top

Base Plate

## Backer Plates Specifications

- Sized for bolt attachment to corresponding anchor models
- Raw uncoated (R)
- HDG hot dip galvanized (G)
- 304 stainless steel (S)

## Ordering Information for Raw Uncoated Models

| Part Name     | Part No. | Anchor Model | Size         | Type        | wt.  |
|---------------|----------|--------------|--------------|-------------|------|
| Backer Plates | 1039-R   | 1037/1301    | 6"x6"x3/8"   | 4 Hole      | 2lb  |
|               | 1084-BPR | CRA 8/12/18  | 16"x16"x3/8" | 52 Hole     | 28lb |
|               | 1085-BPR | CRA 24       | 16"x16"x5/8" | 16 Hole     | 46lb |
|               | 1409-BPR | CRA 24/CRO   | 12"x12"x5/8" | 4 or 8 Hole | 25lb |
|               | 1410-BPR | CRO          | 12"x12"x3/4" |             | 31lb |

Note: HDG models specify BPG. 304 models specify BPS

## No.1039-R

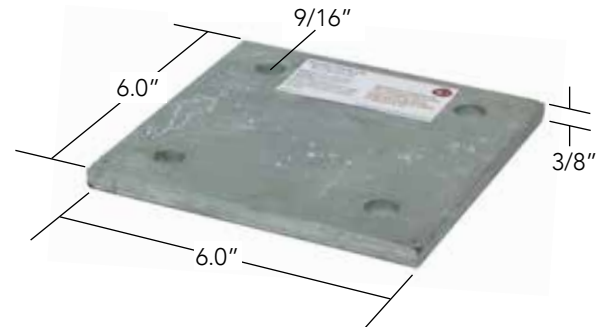

## No.1084-BPR

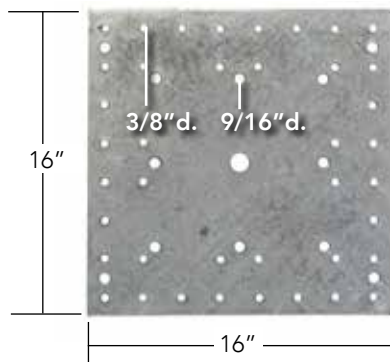

## No.1085-BPR

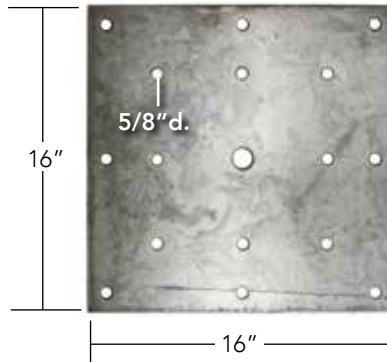

## No.1409-BPR/ No.1410-BPR

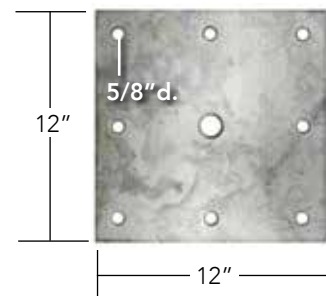

# HLL System Components

## 4-Way HLL Anchors

- Use for rigging several HLL runs in series, at 45 or 90 deg. angles
- Bolt/field weld/concrete embedment installation
- 5,000lb min. tensile strength
- 1-3/8" i.d. cast loop top
- Hot dip galvanized (G) or 304sst (S)
- 4-Way attachment bolt
- Foam filled riser
- English manual
- ANSI Z359.18-17 type A/T\*
- CSA Z259.15.22 type AT
- \*3rd party engineering reports upon request

## Ordering Information

| Part Name | Part No. | Riser Ht. | Base Plate   | Type    | wt.  | 4-Way Top     |
|-----------|----------|-----------|--------------|---------|------|---------------|
| CRA-4-12  | 1032-4G  | 12"       | 16"x16"x3/8" | 52 Hole | 35lb | 1054-G HDG    |
| CRA-4-18  | 1033-4G  | 18"       |              |         | 38lb | 1054-S 304sst |
| CRA-4-24  | 1042-4G  | 24"       | 16"x16"x5/8" | 16 Hole | 65lb | wt. 6.5lb     |

Note: 304sst: CRA-4 specify 4S.

## 4-Way Top

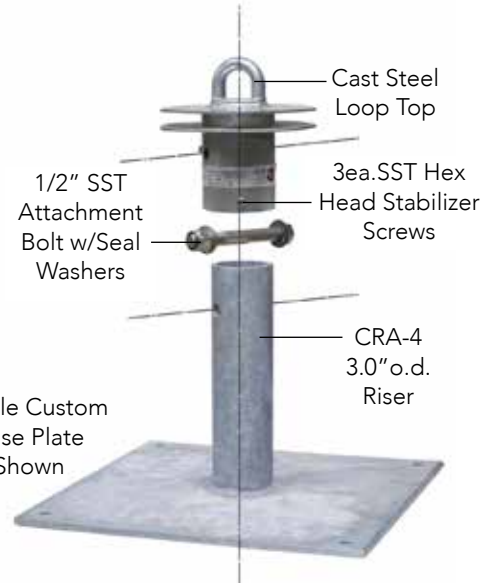

## No.1050-G HLL Rigging Kit

### No.1050-G Kit Contents

| Part No.   | No.Pcs | Finish  | Description         |
|------------|--------|---------|---------------------|
| 5010-SM    | 4ea    | Zinc    | HLL O-Rings         |
| 1058       | 1ea    | 18-8sst | 3/4"x14" Turnbuckle |
|            | 2ea    | 304sst  | 5/8"x3.0" Bolts     |
| 1087-SC    | 2ea    | 304sst  | Absorber Couplers   |
|            | 2ea    | 18-8sst | 3/8"x1.0" Bolts     |
|            | 1ea    |         | 5/8"x2.0" Bolt      |
| 1065-AS    | 1ea    | 304sst  | Spring Absorber     |
| 1081-S     | 1ea    | 304sst  | Coupler             |
|            | 1ea    | 18-8    | 5/8"x2.0" Bolt      |
|            | 1ea    |         | 9/16"x2-1/4" Bolt   |
| 4-Way Bolt | 1ea    | 18-8    | 9/16"x3.0" Bolt     |
| 1057       | 2ea    | HDG     | 3/8" Eye Thimble    |
| 1056       | 6ea    | HDG     | 3/8" Cable Clamps   |

## HLL Rigging Components

- Specified for SAS HLL systems
- Includes all parts for complete on site installation
- All components 5,000lb min. tensile strength
- 4-Way attachment bolt
- English manual
- ANSI Z359.1
- OSHA 1926.502
- \* 3rd party engineering report upon request

## HLL Cable (Wire Rope)

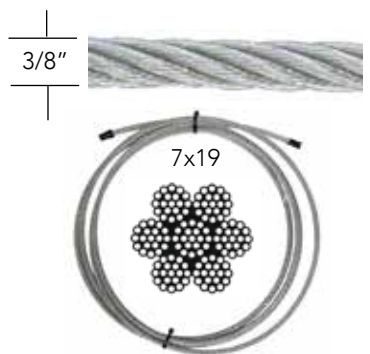

Note: SAS adds an additional 4ft to the HLL cable length as measured from each end anchor or 4-Way top.



## Ordering Information

| Part Name       | Part No. | Type            |          |       |
|-----------------|----------|-----------------|----------|-------|
| HLL Rigging Kit | 1050-G   | Galvanized      |          |       |
|                 | 1050-S*  | Stainless Steel |          |       |
| HLL Cable       | Part No. | Type            | Strength | wt/ft |
| 3/8"x7x19       | 1055-X   | Galv.           | 14,000lb | 0.243 |
|                 | 1055-SX  | 316sst          | 12,500lb |       |

\*Stainless steel rigging kit. Consult SAS Commercial Anchor Catalog.

## SAS Standard HLL Rigging Example



Consult SAS "Commercial Anchor Catalog" for Additional Components

www.superanchor.com 1-855-301-4575

Super Anchor Safety Best Sellers Vol. 1/01-2023

# Fasteners/Carabiners

## SAS Fasteners

All fasteners supplied with anchors and sold as replacements are tested and certified to perform as specified in our instruction manuals. SAS does not recommend using generic non-certified fasteners even when they may appear to be similar types.

## WS Screws

- Use for all SAS anchor models specifying WS screws
- Includes 3/8" hex driver
- Anti-corrosion coating

## Ordering Information

| Part No. | Length | Pcs | Pkg                    |
|----------|--------|-----|------------------------|
| 2084-1.5 | 1.5"   | 25  | Box Inside Retail Pkg. |
| 2084-2.0 | 2.0"   |     |                        |
| 2084-2.5 | 2.5"   |     |                        |
| 2084-3.0 | 3.0"   |     |                        |
| 2084-3.5 | 3.5"   | 10  |                        |

WS Screw



Hex Driver



Retail Package



## Screws/Nails

### Ordering Information

| Part No. | Type                 | Length | Pcs/Pkg   |
|----------|----------------------|--------|-----------|
| 2012-A   | 16d Duplex           | 3.0"   | 36 Retail |
| 2013     | 12d SST Nail         |        |           |
| 2045-3.0 | SST Bugle Head Screw | 3.0"   |           |
| 2045-3.5 |                      | 3.5"   |           |
| 2022     | CRA Hex Screw        | 2.5"   | 40 Retail |

Zinc Coated Duplex



SST Spiral Shank



SST Bugle Head



Hex Head Screw w/Coating



Retail Package



## Fall Protection Carabiners

### No.5001-Z

- Twist Lock zinc plated steel
- 3,600lb gate strength
- 41kN tensile strength
- ANSI-Z359.12-09
- CSA-Z259.12-11
- English Manual



Retail Package



### Ordering Information

| Part No. | Pcs | Pkg    | Wt.   |
|----------|-----|--------|-------|
| 5001-Z   | 1   | Retail | 8.9oz |
| 5006-Z   |     |        | 5.2oz |

### No.5006-Z

- Twist Lock light wt. anodized aluminum
- 3,600lb gate strength
- 24kN tensile strength
- ANSI-Z359.12-09
- CSA-Z259.12-11
- English Manual



Retail Package



### Description

SAS standard issue carabiners specified for use with energy absorbers, lifelines and lanyards. We use only the highest quality ANSI/CSA certified manufacturers for your quality assurance.

# Deluxe™ Full Body Harnesses

The Deluxe Harness™ is one of our best sellers with tens of thousands sold in the USA and Canada since 2009. A fully padded harness designed to support All-Pakka™ tool bags or those mfg. by others. The highest quality materials combined with a unique ergonomic design provides the highest level of comfort distributing the weight of loaded tool bags over the shoulders and hips.

## Features

- 100% polyester w/extra long elastic webbing keepers
- Designed for use with All-Pakka™ tool bags
- 2" wide industrial grade utility belt w/sst grommets
- Dorsal and side D-rings
- Lanyard park/tool holders
- 100% EDC coated hardware
- Quick connect buckles
- 100% USA mfg. and custom logo's on request

## No.6101/6151 Sizing Chart

| Height/Hauteur<br>+/- 2" | Waist Belt<br>Ceinture | Small<br>Petit       | Medium<br>Moyen       | Large<br>Grand        | Long-Large<br>Grand Long | X-Large<br>X-Grand |
|--------------------------|------------------------|----------------------|-----------------------|-----------------------|--------------------------|--------------------|
| 6'-6" 1.98m              |                        |                      |                       |                       |                          |                    |
| 6'-4" 1.9m               |                        |                      |                       |                       |                          |                    |
| 6'-2" 1.8m               |                        |                      |                       |                       |                          |                    |
| 5'-10" 1.7m              |                        |                      |                       |                       |                          |                    |
|                          | 42"<br>106cm           | 48"<br>122cm         | 48"<br>122cm          | 55"<br>140cm          | 62"<br>157cm             |                    |
|                          | 90-130lb<br>40-59kg    | 130-160lb<br>59-72kg | 160-220lb<br>72-100kg | 160-240lb<br>72-108kg | 240-340lb<br>108-154kg   |                    |

## Padded Frame Materials



Comfort Fit Fabric  
100% Polyester Materials  
Resists UV and water Absorption

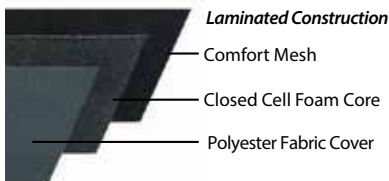

Retail Box  
w/Sizing Chart



## No.6101/6151 Compliance

ANSI Z359.11-14\*

CSA Z259.10.18 class A/P\*\*

\*3rd party Intertek lab report on request

\*\*CSA certification report on request



## No.6101 Ordering Information

| Part No.  | Size     | Webbing | wt.   |
|-----------|----------|---------|-------|
| 6101-GHS  | Sm       | Hi-Viz™ | 5.5lb |
| 6101-GHM  | Med      |         |       |
| 6101-GHL  | Lrg      |         |       |
| 6101-GHLL | Long Lrg |         |       |
| 6101-GHX  | X-Lrg    |         |       |



Quick Connect Buckles

## No.6151 Ordering Information

| Part No.  | Size     | Webbing | wt.   |
|-----------|----------|---------|-------|
| 6151-GHS  | Sm       | Hi-Viz™ | 7.0lb |
| 6151-GHM  | Med      |         |       |
| 6151-GHL  | Lrg      |         |       |
| 6151-GHLL | Long Lrg |         |       |
| 6151-GHX  | X-Lrg    |         |       |

## No.6452

2 Pouch Bag



## No.6453

3 Pouch Bag



## No.6404

Hammer  
Holder



## No.6101-6H



## No.6151-6H

w/Tool Bags +  
Hammer Holder



# Ultra-Viz™ Deluxe Harnesses™

The Ultra-Viz™ Deluxe Harness™ is a SAS exclusive harness model not available from any other mfg. Specified for use where high visibility is required. Same design and features as our Deluxe™ model with the addition of high visibility TRI-LAM3™ and 3M reflective tape. 3rd party certified to comply with ANSI and CSA class 1 high-visibility standards.

## Features

- 100% polyester w/extra long elastic webbing keepers
- Designed for use with All-Pakka™ tool bags
- 2" wide Ultra-Viz™ utility belt w/sst grommets
- Dorsal and side D-rings
- Lanyard park/tool holders
- 100% EDC coated hardware
- Quick connect buckles
- 100% USA mfg. Custom logo's on request

## No.6161™ Tool Bag Harness

Tool bags are mfg. with fluorescent yellow/green high visibility polyester material and 3M reflective tape.

## No.6160/6161 Compliance

ANSI Z359.11-14\*  
CSA Z259.10.18 class A/P\*\*

### High Visibility:

ANSI/ISEA 107-2010 class 1 Type A  
CSA Z96\*\*\*

\*3rd party Intertek lab report on request

\*\*CSA certification report on request

\*\*\*Vartest Laboratories report on request



## No.6160 Ordering Information

| Part No. | Size     | Webbing                                  | wt.   |
|----------|----------|--|-------|
| 6160-M   | Med      | Ultra-Viz™<br>w/3M<br>Reflective<br>Tape | 5.5lb |
| 6160-L   | Lrg      |  |       |
| 6160-LL  | Long Lrg |  |       |
| 6160-X   | X-Lrg    |  |       |

## No.6160



## No.6161™ Ordering Information

| Part No. | Size     | Webbing                                  | wt.   |
|----------|----------|--|-------|
| 6161-M   | Med      | Ultra-Viz™<br>w/3M<br>Reflective<br>Tape | 7.0lb |
| 6161-L   | Lrg      |  |       |
| 6161-LL  | Long Lrg |  |       |
| 6161-X   | X-Lrg    |  |       |

## Sizing Chart see Deluxe™ Harness

### No.6404U

Hammer  
Holder



### No.6161

w/Tool Bags +  
Hammer Holder

## Ultra-Viz™ Webbing

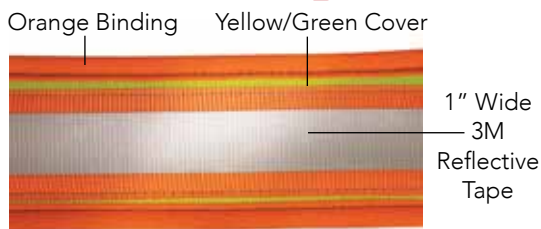

### No.6402U

2 Pouch Bag



## SAS TRI-LAM3™

Comfort Fit Fabric  
100% Polyester Materials  
Resists UV and water Absorption



### No.6403U

3 Pouch Bag



# Tongue Buckle Full Body Harnesses

**No.TB3-6072** is an industry standard harness that's one of our best sellers. Mfg. with a water resistant extra heavy duty padded waist belt and padded back pad. A high quality harness designed for heavy use, yet comfortable enough to wear all day long. Fitted with quick adjustment tongue buckle leg straps and a quick connect chest strap. Ideal for fall restraint or work positioning use.

## Features

- Polyester webbing w/extra long elastic webbing keepers
- EVA solid core foam waist belt
- Padded frame w/breathable mesh
- 2" wide industrial grade utility belt and leg straps w/large grommets
- Dorsal and side D-rings
- Lanyard park/tool holders
- Zinc plated D-rings
- Quick connect chest strap buckle
- **Custom logo's on request**

## Ordering Information

| Part No.     | Size   | Webbing | wt. |
|--------------|--------|---------|-----|
| TB3-6072-HS  | Sm     | Hi-Viz™ | 8lb |
| TB3-6072-HM  | Med    |         |     |
| TB3-6072-HL  | Lrg    |         |     |
| TB3-6072-HX  | X-Lrg  |         |     |
| TB3-6072-H2X | 2X-Lrg |         |     |

## Compliance

ANSI Z359.11-14\*  
 CSA Z259.10.18 class A/P\*\*  
 \*3rd party Intertek lab report on request  
 \*\*CSA certification report on request



## No.TB3-6072-H



## TB3 Model Features

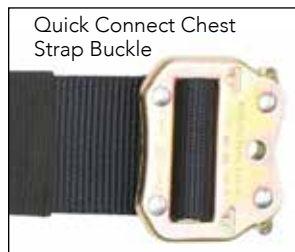

## Retail Box w/Sizing Chart



**No.TB3-6070** is a light weight harness and also one of our best sellers featuring a comfortable padded frame and quick adjustment tongue buckle leg straps. A best choice for workers using lift equipment when side D-rings are required for fall restraint use.

## Compliance

ANSI Z359.11-14\*  
 CSA Z259.10.18 class A/P\*\*  
 \*3rd party Intertek lab report on request  
 \*\*CSA certification report on request

## Ordering Information

| Part No.     | Size   | Webbing | wt. |
|--------------|--------|---------|-----|
| TB3-6070-HS  | Sm     | Hi-Viz™ | 7lb |
| TB3-6070-HM  | Med    |         |     |
| TB3-6070-HL  | Lrg    |         |     |
| TB3-6070-HX  | X-Lrg  |         |     |
| TB3-6070-H2X | 2X-Lrg |         |     |

Hi-Viz™ Webbing



## No.TB3-6070-H



## Features

- Polyester webbing w/extra long elastic webbing keepers
- Padded frame w/breathable mesh
- Dorsal and side D-rings
- Lanyard park/tool holders
- Zinc plated hardware
- Quick connect chest strap buckle
- **Custom logo's on request**



**Retail Box**  
w/Sizing Chart

## TB3-6072/TB3-6070 Sizing Chart

| Height/Hauteur<br>+/- 2" | Small<br>Petit      | Medium<br>Moyen      | Large<br>Grand        | X-Large<br>X-Grand     | 2X-Large<br>2X-Grand   |
|--------------------------|---------------------|----------------------|-----------------------|------------------------|------------------------|
| 6'-8" 2m                 |                     |                      |                       |                        |                        |
| 6'-6" 1.98m              |                     |                      |                       |                        |                        |
| 6'-4" 1.9m               |                     |                      |                       |                        |                        |
| 6'-2" 1.8m               |                     |                      |                       |                        |                        |
| 5'-10" 1.7m              |                     |                      |                       |                        |                        |
|                          | 90-130lb<br>40-59kg | 130-160lb<br>59-72kg | 160-220lb<br>72-100kg | 220-310lb<br>100-140kg | 310-400lb<br>140-180kg |
|                          | 34"<br>86cm         | 38"<br>96cm          | 44"<br>110cm          | 48"<br>122cm           | 52"<br>132cm           |

12

Consult SAS ANSI/CSA Harness Catalogs for additional information

[www.superanchor.com](http://www.superanchor.com) 1-855-301-4575

Super Anchor Safety Best Sellers Vol. 1/01-2023

# Tongue Buckle/Front D-ring Harness

**No.TB3-6067** is our lightest weight and most economical 3 D-ring harness with quick adjust tongue buckle leg straps. Ideal for lift truck, boom lifts or work platforms where fall arrest or fall restraint use are specified.

## Features

- Polyester webbing w/extra long elastic webbing keepers
- Dorsal and side D-rings
- Lanyard park/tool holders
- Zinc plated D-rings
- Quick connect chest strap buckle

## Sizing Chart

Use page 12 sizing chart

## Compliance

ANSI Z359.11-14\*  
CSA Z259.10.18 class A/P\*\*  
\*3rd party Intertek lab report on request  
\*\*CSA certification report on request



## Ordering Information

| Part No.    | Size | Webbing | wt.   |
|-------------|------|---------|-------|
| TB3-6067-HM | Med  | Hi-Viz™ | 4.5lb |
| TB3-6067-HL | Lrg  |         |       |

## No.TB3-6067-H



## Quick Connect Chest Strap



## Tongue Buckle Leg Straps



## Retail Package



**No.FD-6071** is a low cost high quality suspension harness with features you won't find on any other models. 7 D-rings provide connection points for the widest range of fall protection applications. With 6 adjustment points and extra thick water proof padding, this harness provides a high level of comfort. Designed especially for work positioning, this model is ideal for window washers, arborists, tower climbers and vertical wall rebar work.

## Features

- Polyester webbing w/elastic and plastic webbing keepers
- Extra heavy duty EVA solid core foam padding
- Removable lanyard park/tool holders w/elastic webbing keepers
- EDC plated hardware
- Quick connect leg straps

## Sizing Chart

Use page 12 sizing chart

## Compliance

ANSI Z359.11-14/OSHA 1926.502

## Ordering Information

| Part No.   | Size  | Webbing | wt. |
|------------|-------|---------|-----|
| FD-6071-M  | Med   | Hi-Viz™ | 5lb |
| FD-6071-L  | Lrg   |         |     |
| FD-6071-XL | X-Lrg |         |     |

## Class Types

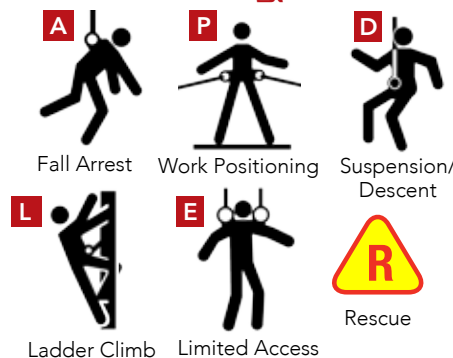

## No.FD-6071



## Waist Belt Cross Section

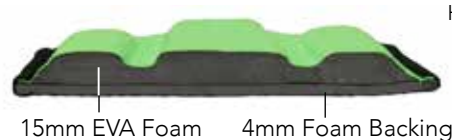



# Pro-Deluxe™ / Fall Arrester™ Harnesses

**No. PD-6101 Pro-Deluxe™** is a 5pt. fully adjustable light weight harness with a fully padded frame and leg straps. This model features closed loop shoulder straps that eliminate annoying loose webbing ends and quick connect buckles. A high quality harness. 100% USA mfg. on request. Consult SAS Harness Catalogs for additional webbing choices.

## Features

- Polyester webbing w/extra long elastic webbing keepers
- Fully padded water resistant TRI-LAM3™ frame and leg straps
- Dorsal D-ring
- Lanyard park/tool holders
- EDC coated hardware
- Quick connect buckles

## Sizing Chart

|                       |                        |                       |                           |
|-----------------------|------------------------|-----------------------|---------------------------|
|                       |                        |                       | 240-340lb<br>108-154kg    |
|                       |                        | 160-240lb<br>72-108kg |                           |
|                       | 130-160lb<br>59-72kg   |                       |                           |
| 90-130lb<br>40-59kg   |                        |                       |                           |
| <b>Small</b><br>Petit | <b>Medium</b><br>Moyen | <b>Large</b><br>Grand | <b>X-Large</b><br>X-Grand |

## Quick Connect Buckles



## Compliance

ANSI Z359.11-14\*  
CSA Z259.10.18 class A\*\*  
\*3rd party Intertek lab report on request  
\*\*CSA certification report on request



## Ordering Information

| Part No.    | Size  | Webbing | wt. |
|-------------|-------|---------|-----|
| PD-6101-GHS | Small | Hi-Viz™ | 3lb |
| PD-6101-GHM | Med   |         |     |
| PD-6101-GHL | Lrg   |         |     |
| PD-6101-GHX | X-Lrg |         |     |

## Padded Frame Materials



Comfort Fit Fabric  
100% Polyester Materials  
Resists UV and water Absorption

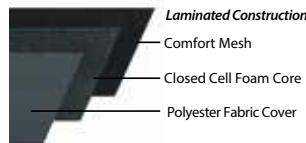

## Retail Box w/Sizing Chart



## No. PD-6101-GH



## No. 6001-H



**No. 6001** is a SAS standard design and one of our best sellers. Fully adjustable 5pt. harness with closed loop shoulder straps that eliminate loose webbing ends. A high quality harness. 100% USA mfg. on request. Consult SAS Harness Catalogs for additional webbing choices.

## Features

- Polyester webbing w/extra long elastic webbing keepers
- Dorsal D-ring
- Pass-thru buckles
- Zinc coated hardware
- Lanyard park/tool holders

## Compliance

ANSI Z359.11-14\*  
CSA Z259.10.18 class A\*\*  
\*3rd party Intertek lab report on request  
\*\*CSA certification report on request



## Sizing Chart

Use No. PD-6101 above

## Retail Package



## Ordering Information

| Part No. | Size  | Webbing | wt.   |
|----------|-------|---------|-------|
| 6001-HS  | Sm    | Hi-Viz™ | 2.5lb |
| 6001-HM  | Med   |         |       |
| 6001-HL  | Lrg   |         |       |
| 6001-HXL | X-Lrg |         |       |

## Pass-thru Buckles



# All-Pakka™ Tool Bags/Utility Belts

**All-Pakka™ Tool Bags** are an industry standard design with several of our own improvements based on years of field testing and end user suggestions. Mfg. with 3 layers of laminated polyester, commercial grade edge binding and reinforced corners, our tool bags are built to last. Perfect for commercial or residential trades.

## Features

- 100% Laminated water resistant polyester materials
- Reinforced pocket corners
- Extra stiff edge binding
- Hook/loop stabilizer strips
- Riveted construction
- Cell phone holder
- Interior and exterior tool holders
- Retail package

## Ordering Information

| Part No. | Type          | Fabric               | wt.    |
|----------|---------------|----------------------|--------|
| 6452     | 2 Pouch       | Gray w/Black Binding | 20oz   |
| 6453     | 3 Pouch       |                      | 24.5oz |
| 6404     | Hammer Holder |                      | 4.3oz  |

## No.6404 Hammer Holder

Sewn and Riveted Construction

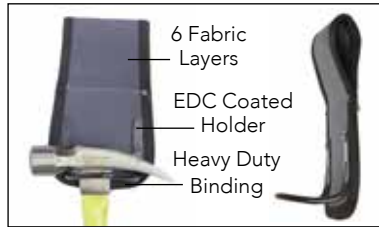

## Retail Package



## No.6452 2 Pouch Bag



## No.6453 3 Pouch Bag



## No.6405 Utility Belt

The number 1 complaint we hear about tool bag belts is they are too thin and the grommets fall out. Our All-Pakka™ utility belt is mfg. with 2" wide extra thick webbing w/sst commercial grade grommets that are specifically designed to stay in place. The SST twin leg tongue buckle provides the strength and stability to hold heavily loaded tool bags in place. You won't find a higher quality more durable utility belt.

## No.6405 Utility Belt

16 Grommet Adjustment

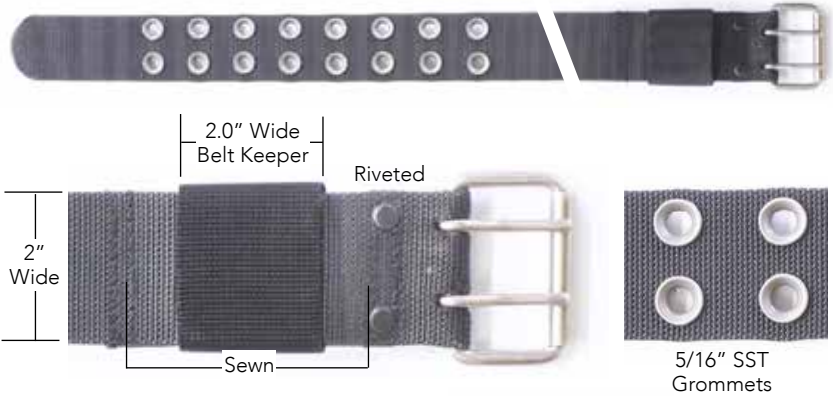

## Features

- 2" wide heavy duty polypro webbing w/2" length belt keeper
- 5/16" commercial grade stainless steel grommets
- Stainless steel tongue buckle
- Riveted and sewn construction
- Retail package

## Ordering Information

| Part No. | Size       | Length |
|----------|------------|--------|
| 6405-S   | Small      | 46"    |
| 6405-L   | Med-Large  | 51"    |
| 6405-LL  | Long-Large | 55"    |
| 6405-XL  | X-Large    | 66"    |

## Retail Package



# All-Pakka™ Tool Bag Combo/Waist Belt

**All-Pakka™ Tool Bag Combo** is a popular industry standard design that incorporates a padded waist belt, utility belt, tool bags and hammer holder. Widely used by most construction trades in one form or another. Our waist belts are mfg. with TRI-LAM3™ solid core foam padding that does not absorb water and sized to fit without modification. Overlapping hook/loop closure provides a snug fit that stays in place and is super comfortable. A high quality extremely durable tool bag system.

## Features

- All-Pakka™ tool bags and hammer holder
- 100% polyester materials
- TRI-LAM3™ full padded overlapping hook/loop waist belt
- Continuous loop stabilizer strip engages tool bag hook strip
- Retail box

## Ordering Information

| Part No. | Size     | Waist Belt | Utility Belt | wt.   |
|----------|----------|------------|--------------|-------|
| 6400-GS  | Sm       | 42"        | 46"          | 3.5lb |
| 6400-GL  | Med/Lrg  | 48"        | 51"          |       |
| 6400-GLL | Long-Lrg | 55"        | 55"          |       |
| 6400-GX  | X-Lrg    | 62"        | 66"          |       |

## Retail Box



## No.6404 Hammer Holder



## Waist Belt Materials

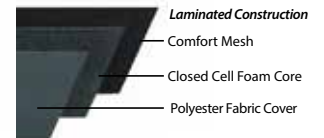

Hammer not included

## No.6407-G Padded Waist Belt

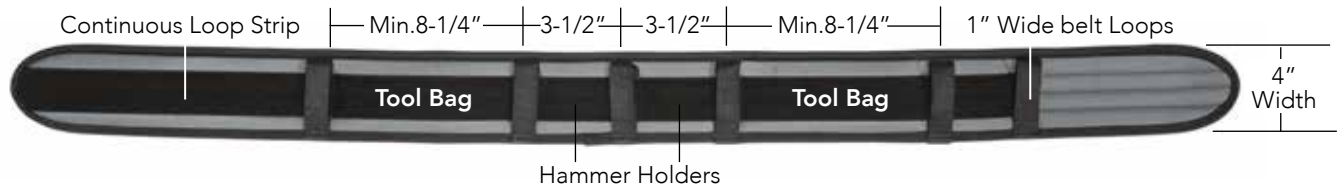

**All-Pakka™ Waist Belt** is ideal for creating a personalized tool bag system using your own tool bags and belt or other All-Pakka™ components.

## Features

- 100% polyester materials
- TRI-LAM3™ full padded overlapping hook/loop waist belt
- Continuous loop stabilizer strip engages tool bag hook strip

## Ordering Information

| Part No. | Size     | Length | wt. |
|----------|----------|--------|-----|
| 6407-GS  | Sm       | 42"    | 5lb |
| 6407-GL  | Med/Lrg  | 48"    |     |
| 6407-GLL | Long-Lrg | 55"    |     |
| 6407-GX  | X-Lrg    | 62"    |     |

# Personal™ Energy Absorbers

**Personal Energy Absorbers (E/A's)**, are a critical component in meeting fall protection standards and are required when workers are exposed to free fall hazards. We mfg. a complete line of E/A's at our Monroe, WA USA factory.



## Features

- 100% polyester webbing
- ANSI/CSA certified tear webbing.
- 3,600lb(16kN) gate strength connectors
- Loop end wear pads
- Clear PVC shock pack cover
- Date of mfg. serial numbered w/annual inspection label
- Fall indicator
- English/Spanish/French labels and instruction manuals
- Supplied in retail package

## Compliance

ANSI Z359.13-13  
CSA Z259.11-17

## Performance Specifications

**User wt's:** ANSI=130-310lb (140kg)  
CSA=135-310lb (140kg)  
**Max. Arrest Force:** 1,800lb (8kN)  
**Avg. Arrest Force:** 900lb (4kN)  
**Max. Deployment:** 48" (1.2m)  
**Max. Free Fall:** 6ft (1.8m)

## Ultra-Lite™ Dee-Loop E/A's

The lightest E/A we mfg. attaches directly to the harness dorsal D-ring via a chinch knot. The elimination of a class 1 connector at the A-end results in a significant reduction in the components service weight and provides a higher level of comfort. Consult SAS Absorber catalog for additional model types. Mfg. exclusively at our Monroe, WA USA factory.

## Harness D-ring Attachment

Feed Dee-Loop thru D-ring

Feed shock pack thru Dee-Loop



Cinch tightly to D-ring

**No.3004**

**No.6182**

**No.6184**  
w/No.5006-Z  
Anodized Alum  
Carabiner

**No.6193**

Ultra-Lite™  
Dee-Loop

"A"  
end

**Service Length**  
Measured from  
connector  
end to  
connector  
end

**Service Length**  
Cinched  
26.0"

No.4015-M  
Integral  
Adjuster  
Rope Grab

"B"  
end

## Ordering Information

| Part No. | Length | wt.  | A-end     | B-end             | wt.  |
|----------|--------|------|-----------|-------------------|------|
| 3004     | 23.0"  | 38oz | Snaphook  | 4015-M            | 38oz |
| 6182     | 24.0"  | 27oz |           | No.5004<br>D-ring | 27oz |
| 6184     | 23.0"  | 18oz | Carabiner | No.5004<br>D-ring | 18oz |
| 6193     | 26.0"  | 14oz | Dee-Loop  |                   | 14oz |

## Retail Package



# Flex™ Energy Absorbing Lanyards

**Flex™ Energy Absorbers** are designed to expand and contract during use. They have an internal shock absorbing component to reduce free fall forces. Ideal for use with lift equipment or stationary work areas working with lift equipment.

## Features

- Lightweight expandable service length up to 6ft
- Fall indicator and annual inspection label
- 3,600lb(16kN) gate strength connectors
- Supplied in retail box

## Performance Specifications

**User wt's:** 130-310lb  
**Max. Arrest Force:** 1,800lb  
**Max. Deployment:** 48"  
**Max. Free Fall:** 6ft  
**Fully Deployed:** 10ft

**Note:** Due to availability some lanyards may be supplied with black webbing. Ask when ordering.

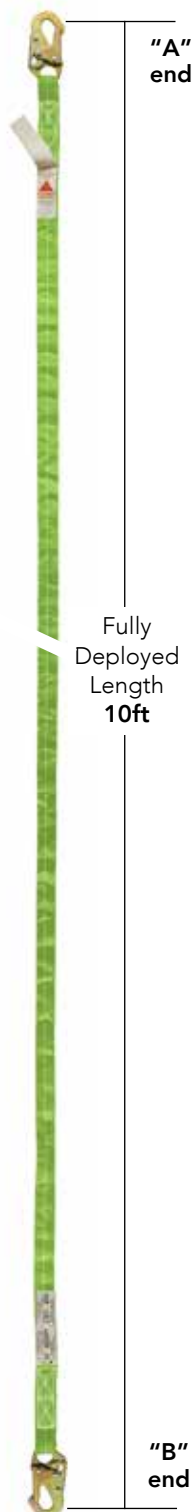

**No.6501**

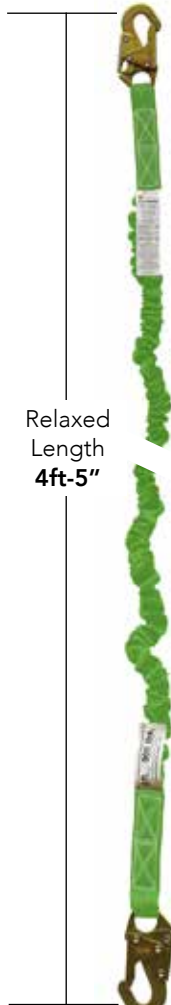

Relaxed Length  
**4ft-5"**

△ **No.6502**



△ **No.6503**



△ **No.6504**



**No.6501**  
Retail Package



△ **Retail Box**



## Labels

**PID**

Fall Indicator



**Annual Inspection Label**

## Ordering Information

| Part No. | A-end    | B-end        | wt.   | Service Lengths        |                         |                               |
|----------|----------|--------------|-------|------------------------|-------------------------|-------------------------------|
|          |          |              |       | Relaxed Length 4ft-5in | Max. Service Length 6ft | Fully Deployed Free-Fall 10ft |
| 6501     | Snaphook | Snaphook     | 2.5lb | Relaxed Length 4ft-5in | Max. Service Length 6ft | Fully Deployed Free-Fall 10ft |
| 6502     |          | Rebarhook    | 3.5lb |                        |                         |                               |
| 6503     |          | 2 Snaphooks  | 4lb   |                        |                         |                               |
| 6504     |          | 2 Rebarhooks | 6lb   |                        |                         |                               |

## Compliance

ANSI Z359.13-13  
 OSHA 1926.502

# Extender Lanyards

## Extender Lanyards

### Extender Lanyards

attach to the dorsal D-ring of a full body harness providing additional length required when used with other fall protection equipment. Non-energy absorbing. Mfg. at SAS factory Monroe, WA USA

### Features

- 100% polyester
- 3,600lb gate strength connectors
- PVC wear pads
- Inspection label



All extender lanyards are supplied in a retail package



### Ordering Information

| Part No. | A-end       | B-end       | Length | wt./oz |
|----------|-------------|-------------|--------|--------|
| 6002-C   | △ Carabiner | Sm D-ring   | 18"    | 11     |
| 6002-CL  |             | Web Loop    | 17"    | 8      |
| 6002-CC  | ▲ Carabiner | ▲ Carabiner | 22"    | 14     |
| 6002-S   | Snaphook    | Sm D-ring   | 19"    | 19     |
| 6002-SL  |             | Web Loop    | 18"    | 17     |
| 6002-SS  |             | Snaphook    | 22"    | 30     |

△ Anodized Aluminum Carabiner

▲ Captive Non-removable Aluminum Carabiner

### Compliance

ANSI Z359.13-13  
OSHA 1926.502

### Dee-Loop™ Extender Lanyards

are attached directly to the harness dorsal D-ring eliminating a class 1 connector, resulting in lighter weight and greater comfort.

### Ordering Information

| Part No. | B-end       | Length | wt./oz |
|----------|-------------|--------|--------|
| 6002-D   | Sm D-ring   | 19"    | 6      |
| 6002-DC  | △ Carabiner | 22"    | 9      |
| 6002-DL  | Web Loop    | 18"    | 4      |
| 6002-DS  | Snaphook    | 23"    | 17     |
| 6002-DCC | ▲ Carabiner | 22"    | 9      |

△ Anodized Aluminum Carabiner

▲ Captive Non-removable Aluminum Carabiner



# Adjustable Rope/2-D Lanyards

## No.4110

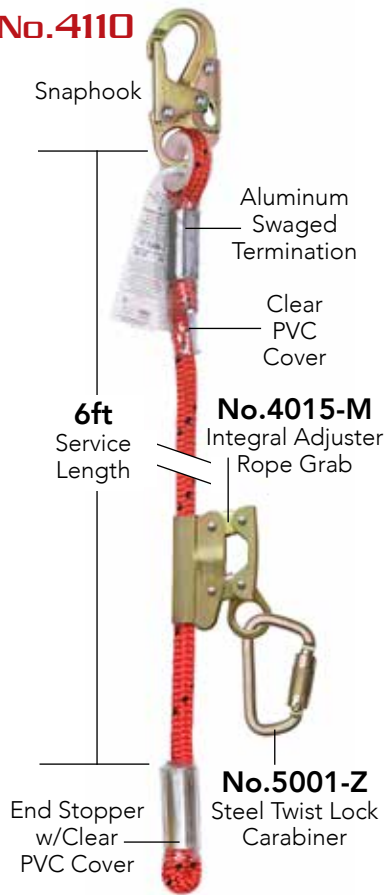

**No.4110 Adjustable Rope Lanyard** is designed specifically for use in lift buckets, boom lifts and scissor lifts.

### Features

- 5/8" kernmantle rope
- Aluminum swaged terminations w/clear PVC shrink tube covers
- Captive zinc plated rope grab
- 3,600lb gate strength connectors
- PID and inspection label
- Instruction manual
- Mfg. at Super Anchor Safety factory in Monroe, WA USA

### Retail Package



### Ordering Information

| Part No. | A-end    | Rope Grab | Carabiner | wt.   |
|----------|----------|-----------|-----------|-------|
| 4110     | Snaphook | No.4015-M | No.5001-Z | 4.0lb |

### Compliance

ANSI Z359.13-13  
OSHA 1926.502



## 2-D Lanyards™

2-D lanyards link the side D-rings of a full body harness for fall restraint or work positioning. A SAS exclusive mfg. at our factory in Monroe, WA USA

### Features

- Compact and lightweight
- 4,000lb min. tensile strength
- 3/16" Wire rope w/steel thimbles
- 3,600lb gate strength connectors
- PID and inspection label
- Instruction manual

### Ordering Information

| Part No. | Carabiner       | wt./oz |
|----------|-----------------|--------|
| 6515-C   | Δ No.5000-Z     | 17     |
| 6515-CA  | Δ No.5006-Z     |        |
| 6515-CS  | Steel No.5001-Z | 25     |

Δ Aluminum twist lock carabiners w/anodized coating



20

### Retail Package



### Compliance

ANSI Z359.13-13  
OSHA 1926.502

# Web Lanyards

## Adjustable Length Web Lanyard

### No.6014-72A Adjustable Length Web Lanyard

is specified for fall restraint use. Attaches to a full body harness dorsal D-ring or side D-rings. Mfg. at Super Anchor Safety factory in Monroe, WA USA

### Ordering Information

| Part No. | A-end    | B-end    | wt. |
|----------|----------|----------|-----|
| 6014-72A | Snaphook | Snaphook | 36  |

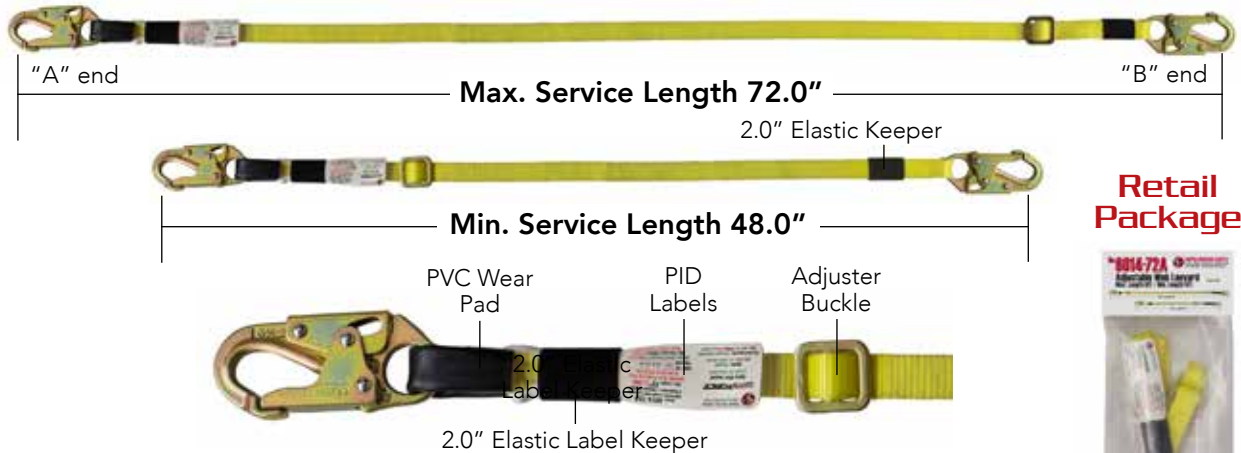

### Retail Package



### Features

- 8,700lb 1.0" nylon webbing
- 3,600lb gate strength connectors
- 5,000lb zinc plated adjuster buckle
- Non-energy absorbing
- Serial numbered
- PID and inspection label
- Instruction manual
- Mfg. at Super Anchor Safety factory in Monroe, WA USA

### Compliance

ANSI Z359.13-13  
OSHA 1926.502

## Fixed Length Web Lanyards

Fixed Length Web Lanyards are specified for fall restraint use but may be used with an energy absorber for fall arrest. Mfg. at Super Anchor Safety factory in Monroe, WA USA

### Features

- 8,700lb 1.0" nylon webbing
- 3,600lb gate strength connectors
- Non-energy absorbing
- Serial numbered
- Instruction manual
- PID and inspection label



No.6014-72W w/B-end Snaphook

### Ordering Information

| Part No. | Length | A-end    | B-end    | wt./oz   |
|----------|--------|----------|----------|----------|
| 6014-18  | 18.0"  | Snaphook | Loop End | 16       |
| 6014-24  | 24.0"  |          |          | 17       |
| 6014-36  | 36.0"  |          |          | 19       |
| 6014-48  | 48.0"  |          |          | 22       |
| 6014-60  | 60.0"  |          |          | 24       |
| 6014-72  | 72.0"  |          |          | 27       |
| 6014-72W | 72.0"  |          |          | Snaphook |

### Compliance

ANSI Z359.13-13  
OSHA 1926.502

### Retail Package



### Custom Lanyards

Consult our Custom Web Lanyard Worksheet for lanyards mfg. with several connector options and lengths.



# MAX-V™ Fall Protection Kit

## Features

- No.6069 Value™ Universal size 5pt full body harness w/Hi-Viz™ polyester webbing w/serial number and inspection label
- 3.0" length elastic webbing keepers
- No.6181 energy absorber with "A" and "B" end 3,600lb gate strength snaphooks
- No.4015-M integral adjuster rope grab
- Maxima™ co-polymer lifeline with aluminum swaged termination and clear PVC shrink tube cover
- No.3013-D Hinge-2™ adjustable slope reusable anchor with dual fastener holes for nails or WS screws
- No.2012-A 36pc zinc plated duplex nails
- English/Spanish 20pg instruction manual

## ANSI Compliance

**Harness:** Z359.11-14

**Energy Absorber:** Z359.13-13

**Lifeline:** Z359.15-14

**Hinge2:** Z359.18-17 Type A

**Max-V™ No.3200-B** is our version of an industry standard complete fall protection kit supplied in an attractive retail 5 gal bucket. The No.6181 energy absorber provides a quick disconnect from the integral adjuster (rope grab). Assembled at our SAS factory in Monroe, WA USA



# MAX™ Fall Protection Kit

## Features

- No.6001™ sized to fit 5pt full body harness w/Hi-Viz™ polyester webbing w/serial number and inspection label
- 3.0" length elastic webbing keepers
- No.3004 energy absorber with "A" end 3,600lb strength snaphook
- No.4015-M integral adjuster rope grab
- Value™ polyolefin lifeline with aluminum swaged termination and clear PVC shrink tube cover
- No.3013-D Hinge-2™ adjustable slope reusable anchor with dual fastener holes for nails or WS screws
- No.2012-A 36pc zinc plated duplex nails
- No.3005-C 2"x48" polyester tie-off strap
- English/Spanish 20pg instruction manual

## ANSI Compliance

**Harness:** Z359.11-14

**Energy Absorber:** Z359.13-13

**Lifeline:** Z359.15-14

**Hinge2:** Z359.18-17 Type A

**Max™ No.3001** is a deluxe version complete fall protection kit supplied in an attractive retail 5 gal bucket and one of our most popular sellers. Supplied with a 5 point user sized full body harness and poly-dacron lifeline. Includes roof anchor and tie-off strap. Assembled at our SAS factory in Monroe, WA USA



**Max Bucket**  
5 gallon



**Side Panel**  
English  
Spanish  
French  
Child  
Warning!

English Spanish  
20 page manual

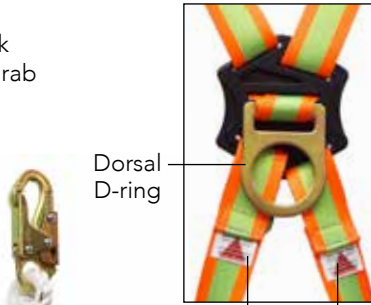

Dorsal  
D-ring



Aluminum  
Swaging



**Value™**  
3 Strand Lifeline

Fall  
Indicators  
3.0" Elastic  
Webbing  
Keepers

**No.6001 Value™**  
5 Point Harness



Hi-Viz™  
Webbing

Pass-Thru  
Buckles

Lanyard  
Parks

**No.3004**  
Energy Absorber



Service  
Length  
27.0"

**No.4015-M**  
Integral Adjuster  
Rope Grab

## 50ft Ordering Information

| Part No.  | Size  | Lifeline | wt/lb |
|-----------|-------|----------|-------|
| 3001-50HS | Sm    | 50ft.    | 17    |
| 3001-50HM | Med   |          |       |
| 3001-50HL | Lrg   |          |       |
| 3001-50HX | X-Lrg |          |       |

Full Pallet=48 units

## 25ft Ordering Information

| Part No.  | Size  | Lifeline | wt/lb |
|-----------|-------|----------|-------|
| 3001-25HS | Sm    | 25ft.    | 15    |
| 3001-25HM | Med   |          |       |
| 3001-25HL | Lrg   |          |       |
| 3001-25HX | X-Lrg |          |       |

Full Pallet=48 units

**No.3005-C**  
48" Tie-Off Strap



**No.3013-D**  
Hinge-2™ Adjustable  
Reusable Anchor



**No.2012-A**  
36pc Zinc Plated  
Duplex Nails



2 Size Fastener  
Holes for Nails  
or WS Screws

# Lifelines

Synthetic fiber vertical lifelines are a key component of a personal fall protection system and are used with a rope grab for position adjustment. SAS offers several rope types and custom mfg.

## All SAS Lifelines

- Assembled and swaged at SAS factory in Monroe, WA USA
- PID, inspection label and serial no.
- Aluminum swage w/clear PVC cover
- 3,600lb gate strength snaphook
- English/Spanish instruction manual
- Compatible with all SAS rope grabs

### Compliance

- ANSI Z359.1-07/OSHA 1926.502
- User wt.: 340lb

**No.4034 Deluxe™ Lifeline** is a 12 strand commercial grade rope that is mfg. in the USA from the highest quality materials. Extremely durable.

### Features

- 5/8" (16mm) d. polyolefin
- 11,600lb tensile strength
- UV resistant coating
- Red color for high visibility
- No.4015 SuperGrab™
- Supplied in a retail box

### Ordering Information

| Part No.  | Length | wt/lb |
|-----------|--------|-------|
| 4034-30SG | 30ft   | 4     |
| 4034-50SG | 50ft   | 5     |

## No.4034-5G



## No.4015 SuperGrab™

## SAS Factory Swage



English/Spanish  
20 Page Manual



## Retail Box



## Custom Mfg.

Custom length and connector types available. Contact SAS sales team.

PVC  
Adhesive  
Shrink  
Tube

## Retail Box



**No.4020 Value™ Lifeline** is an industry standard low cost high quality 3 strand lifeline

### Features

- 5/8" (16mm) d. polyolefin
- 9,700lb tensile strength
- Supplied in a retail box

## Retail Box



**No.4083 Maxima™ Lifeline** is our most economical 3 strand lifeline.

### Features

- 5/8" (16mm) d. co-polymer
- 10,582lb tensile strength
- Supplied in a retail box

### Ordering Information

| Part No. | Length | wt/lb |
|----------|--------|-------|
| 4020-25  | 25ft   | 4     |
| 4020-30  | 30ft   | 4     |
| 4020-50  | 50ft   | 5     |
| 4020-75  | 75ft   | 7     |
| 4020-100 | 100ft  | 10    |

### Ordering Information

| Part No. | Length | wt/lb |
|----------|--------|-------|
| 4083-25  | 25ft   | 4     |
| 4083-30  | 30ft   | 4     |
| 4083-50  | 50ft   | 5     |
| 4083-100 | 100ft  | 9     |



# Fall Arrester/Rope Grabs

Personal fall protection lifelines require a rope grab for position adjustment. SAS offers 4 different models that are compatible with 5/8" d. synthetic rope. Supplied in retail packages with PID, inspection labels and instruction manuals.

## No.4015-Z Features

- Zinc plated steel 16kN tensile strength
- Panic grab function
- Single direction locking
- Use with 5/8" (16mm) lifelines

### Compliance

ANSI Z359.15-14

## No.4015-Z Fall Arrester w/Panic Grab

Industry standard mechanical rope grab with a hinged gate for easy attachment or removal from the lifeline.



## No.4015-M Features

- Zinc plated steel 16kN tensile strength
- Captive lifeline attachment
- Single direction locking
- Use with 5/8" (16mm) lifelines

Industry standard mechanical rope grab easily adjusts position up or down on the lifeline. Captive type is not removable.

**Compliance:** ANSI Z359.15-14

## All Rope Grabs Shipped in a Retail Package



## Non Mechanical Prussic Type Rope Grabs

A best seller for over 30 years. Easily adjusts up or down on the lifeline, holds position and locks in both directions. **Certification:** 3rd party engineering report and US Dept. of Labor (OSHA) compliance letter is available on request.



## No.4015 Features

- Ergonomic hand hold w/fall indicator function.
- 5,000lb min. tensile strength
- Captive lifeline attachment
- Use with 5/8" and 3/4" lifelines

## Ordering Information

| Part No. | Type                | Attachment | Deceleration |
|----------|---------------------|------------|--------------|
| 4015-Z   | ▲ Fall Arrester     | Removable  | Avg. 24"     |
| △ 4015-C |                     |            |              |
| 4015-M   | ▲ Integral Adjuster | Captive    | Avg. 12"     |
| 4015     | SuperGrab™          |            |              |
| 4015-V   | ValueGrab™          |            |              |

△ Stainless Steel ▲ Single direction locking.



## No.4015-V Features

- 5,000lb min. tensile strength
- 3,600lb gate strength snaphook
- Aluminum swage w/PVC cover
- Captive lifeline attachment
- Use with 5/8" and 3/4" lifelines

# SideWinder® Self Retracting Lifeline

**SideWinder™** Self Retracting Lifelines (SRLs), are designed with a spring loaded retractable lifeline specified for personal fall arrest and work positioning. The internal braking system reduces free fall forces while arresting the fall. Our SideWinder® models have been in service for over 15 years and have proven to be very reliable. SAS provides factory service, repair and annual inspections with short lead times and we maintain an extensive inventory of spare parts.

## Features

- Heavy duty ABS housing
- Integrated carry handle/anchorage attachment w/No.5001-Z twist lock carabiner
- 3/16" galvanized cable
- Fall indicator snaphook
- Permanent engraved serial No. and part number
- Replacement English/ Spanish PID labels
- Retail box

## Compliance

ANSI Z359.14-12 Class B

## Integrated Handle

One piece handle supports the SRL anchorage attachment providing a fail-safe connection between casing sides.

## Braking System

In the event of a fall the internal energy absorbing braking system reduces free fall forces to less than 1,125lb.

## Performance Specifications

**Min. Strength:** 3,300lb (15kN)

**Cable:** 3/16" Galv. Steel (4.8mm)

**User wt.:** 310lb (140kg)

**Max. Arrest Distance:** 54"(1.4m)

**Avg. Max.Arrest Force:** 1,125lb (5kN)

## Ordering Information

| Part No. | Length | wt/lb |
|----------|--------|-------|
| 2904k    | 20ft   | 12    |
| 2903k    | 30ft   | 16    |
| 2901k    | 50ft   | 18    |



Retail Box

## Permanent Engraving

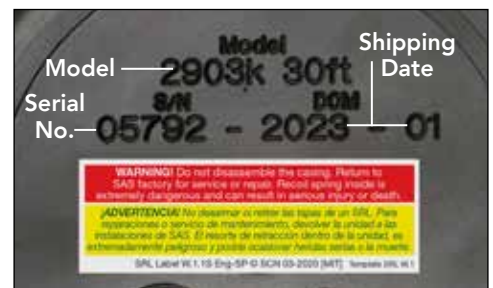

No.2903k 30ft  
Top Seller

PID/Inspection Labels

ABS Casing

No.5001-Z Carabiner

Engraved Part/Serial No.



Integrated Handle

Brake Locks

Internal Brake System



Steel Cable Guide

Ergonomic Grip Handle

Fall Indicator

Swivel Snaphook

# TossR® Self Retracting Lifeline

## TossR™ Class A SRL

Lightweight and compact, Toss'R™ models are ideal for confined spaces, work platforms and lift equipment. Non-repairable class A are disposed of when subjected to a fall or damaged in service. That's why we named it the Toss'R.

### Lift Truck



### Features

- Heavy duty ABS housing
- UHMWPE 4,500lb webbing
- Swivel attachment w/No.5001-Z twist lock carabiner
- 6kN external energy absorber
- Fall indicator label
- Serial No. and part number
- English/ Spanish PID labels
- Retail box

### Compliance

ANSI Z359.14-12 Class A

### Performance Specifications

**Webbing Min. Strength:** 4,500lb (20kN)

**Webbing Type:** UHMWPE 19mm

**User wt.:** ANSI Z359.14-12 =310lb(140-kg)

OSHA 1926.502 =410lb(190kg)

**Max. Arrest Distance:** 24"(6m)

**Avg. Max.Arrest Force:** 1,350lb (6kN)

**Energy Absorber Deployment:** 48"

### No.2990-A6 6ft

No.5001-Z Carabiner

PID Label

Polymer Casing

Energy Absorber

Fall Indicator Inspection Label

Aluminum Anodized Twist Lock Carabiner

18-1/2" Length

### Boom Lift



### Ordering Information

| Part No. | Length | wt/lb |
|----------|--------|-------|
| 2990-A6  | 6ft    | 2.5   |
| 2990-A11 | 11ft   | 3.5   |

Polyethylene (UHMWPE)  
19mm Webbing



### Retail Box

### PID Label Data Entry

|                          |                        |                                |  |  |
|--------------------------|------------------------|--------------------------------|--|--|
| Model<br>2990-A6         |                        | TossR™ 6ft(1.8m)<br>Web Length |  | User Enters<br>Date of<br>First<br>Use |
| Lot mfg. Date<br>01-2022 | Serial No.<br>A-123456 | First Service<br>01-2023       |  |  |

# Accessories

## ALL-Pakka™ Cargo Bags

Ideal for storing fall protection equipment. Our bags are mfg. in two sizes with high quality materials built to last. These bags can be personalized with your own company logo.

### No.6420 Large



### No.6420U Large



## Features

- 3 layer laminated polyester waterproof fabric
- Commercial grade zipper
- Reinforced steel frame closure
- Extra heavy duty bottom panel
- 5 exterior pockets
- 6 interior pockets
- Writable name plate



## Ordering Information

| Part No. | Color        | Size  | Dimensions        | Cu/in | wt/lb |
|----------|--------------|-------|-------------------|-------|-------|
| 6420     | Black/Silver | Large | H=12" L=24" W=10" | 2,800 | 3.75  |
| 6420U    | Green/Gray   |       |                   |       |       |
| 6421     | Black/Silver | Jumbo | H=16" L=28" W=12" | 5,380 | 4.25  |
| Δ 6421U  | Green/Gray   |       |                   |       |       |

Δ Does not have writeable label

## Custom Logo's

Logos are sewn attached using your artwork, colors, and shape



## Trauma Suspension Ladder

OSHA and CSA require that workers suspended in a full body harness must be rescued promptly to avoid serious injury or death.

## Ordering Information

| Part No. | Part Name                | wt/lb |
|----------|--------------------------|-------|
| 6060     | Trauma Suspension Ladder | 3.6   |

## Features

- 3/4" polypro waterproof webbing steps
- Polyester storage bag
- Compact/lightweight
- Reusable
- English/Spanish/French labels and instructions
- Attaches to harness webbing



## Retail Package



### Webbing Cinch Strap



### Attaches to Harness Leg Strap



60.0"  
Fully  
Extended

8 Steps

# Accessories

## No.6427 Tool Tethers

Elastic webbing tool tethers attach to a full body harness or tool belt. Ideal for work areas or heights where dropped tools pose a safety hazard.



## Features

- Commercial grade anodized twist lock carabiners
- 3/4" 2,000lb strength elastic webbing
- 15lb tool weight capacity
- Adjustable cinch cord w/cinch lock

## Carabiners



## No.6427-C1 No.6427-CS1 No.6427-C2

Single Leg w/Captive Carabiner      Single Leg w/Swivel Carabiner      Twin Leg w/Captive Carabiner

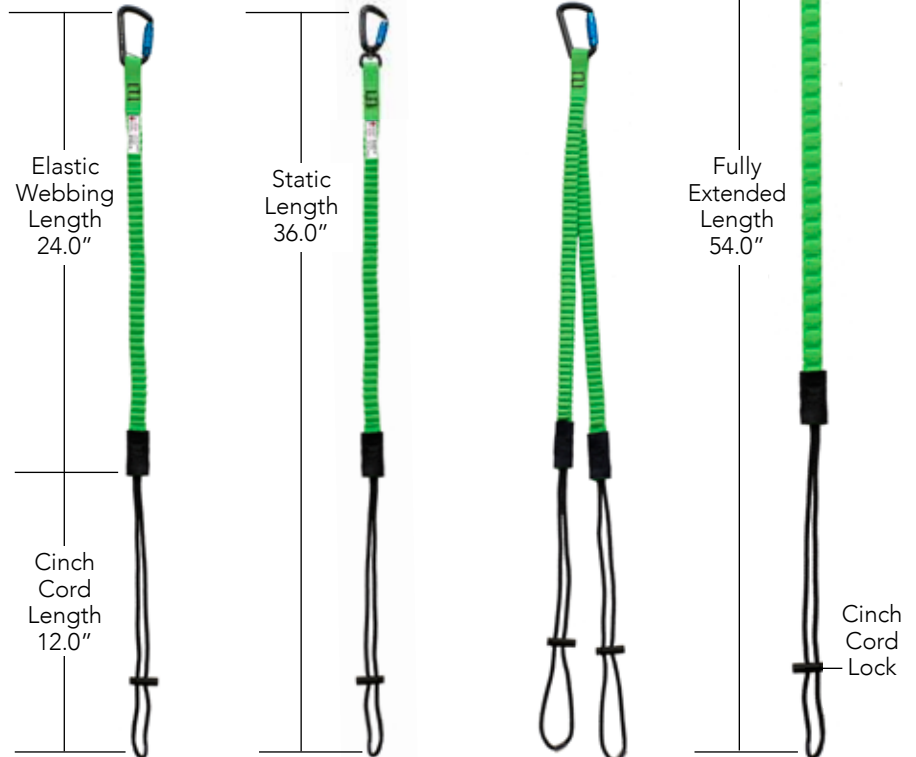

## Ordering Information

| Part No. | Part Name  | Carabiner | wt/lb |
|----------|------------|-----------|-------|
| 6427-C1  | Single Leg | Captive   | 3     |
| 6427-CS1 |            | Swivel    |       |
| 6427-C2  | Twin Leg   | Captive   | 4.5   |

## No.5020-LP2 Lanyard Parks

ANSI Z359.11-14 require that full body harnesses are fitted with lanyard parks. Our accessory parks provide an easy way to upgrade any harness.

## Features

- Fits 1-1/2" up to 2.5" webbing widths
- 100% polyester
- Double sided hook/loop wrap around strap
- Max. 120lb breakaway force

## Ordering Information

| Part No. | Part Name    | wt/lb |
|----------|--------------|-------|
| 5020-LP2 | Lanyard Park | 2.4   |

8.0" Hook/Loop Webbing Wrap



## 2pc Retail Package





# Accessories

**No.1095 Ladder Leash™** is a reusable surface mounted ladder tie-off with removable nail plate. Ideal for securing ladders to a wood framed structure. Installs with a single nail. Adjustable length webbing straps.

## Features

- Zinc plated nail plate
- 2ea Ladder Leash™
- 2ea spiral shank sst nails
- PID and inspection label
- Instruction manual

## Ordering Information

| Part No. | Part Name         | Fasteners | wt/lb |
|----------|-------------------|-----------|-------|
| 1095     | 2pc Ladder Leash™ | SST nails | 1     |



**Installation**  
Attach nail plate thru sheathing into a top chord on each side of the ladder location.

Install roofing over the nail plate to provide a temporary ladder anchor to prevent unwanted movement.



Remove by tapping the angle edge of the nail plate and reuse on the next project.



## 2pc Retail Package





# SUPER ANCHOR SAFETY

## FALL PROTECTION EQUIPMENT

17731 147th Street SE Monroe, WA 98272

[425]-488-8868

[www.superanchor.com](http://www.superanchor.com)

1-855-301-4575

