

HLL Loop Top Couplers/Swaging Examples

No.1090/1090-S Loop Tops

Designed for use with 3.0"od. risers

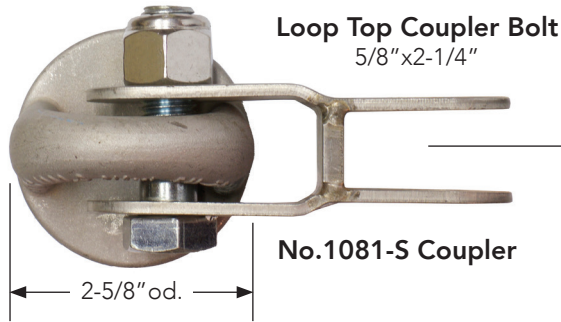

Coupler Compatibility

No.1090 and No.1093 loop tops have significant differences in dimension requiring specific coupler sizes to be used in rigging. Note: "S" part number suffix = stainless steel part.

No.1081-S/1086-S Couplers

Are compatible w/3/8" eye thimbles used for standard HLL "B" end rigging



No.1057/1057-S
3/8" Eye Thimble

No.1093/1093-S Loop Tops

Designed for use with 4.5"od. risers

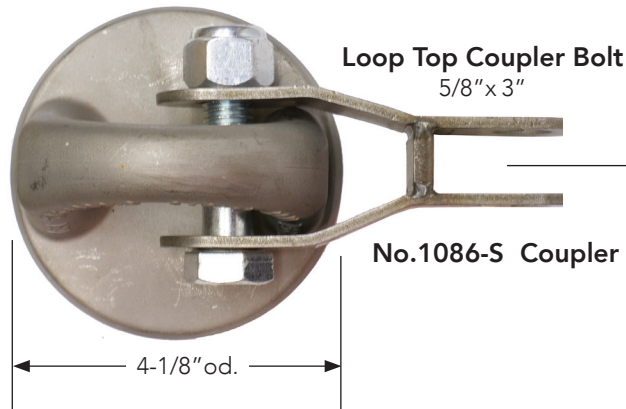

HLL Cable Swaging Options

3 Clamp On-Site Field Swaging

Spacing Approx. 4" oc.

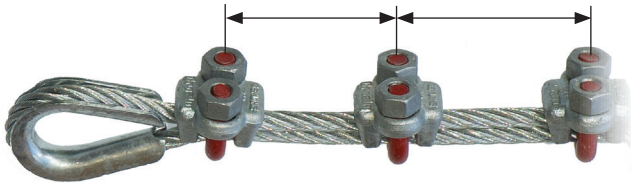

Cable Clamps

No.1056 Galv.

No.1056-S SST

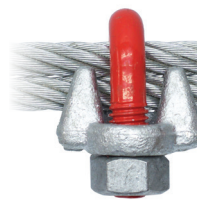

SAS Factory Swaging



8001-CFS On-Site Swaging System

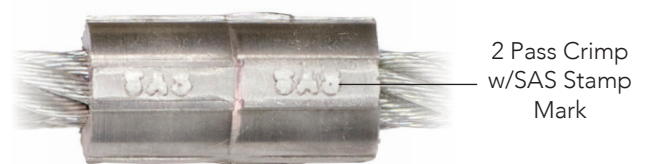

Note: Hyd. swaging requires 2 alum. sleeves.